

LZ23232

1/3 type Color **CCD** Area Sensor for PAL

DESCRIPTION

LZ23232 is a 1/3-type (6.0 mm) solid-state image sensor that consists of PN photo-diodes and CCDs (charge-coupled devices). Having approximately 320000 pixels (horizontal 542 X vertical 562), the sensor provides a high resolution stable color normal or mirror image.

FEATURES

- Number of pixels : 512 (H) X 582 (V)
Pixel pitch : 9.6 μm (H) X 6.3 μm (V)
Number of optical black pixels
: Horizontal; front 2 and rear 28
- Complementary color filters of Mg, G, Cy and Ye
- Low fixed pattern noise and lag
- No sticking and no image distortion
- Blooming suppression structure
- Built-in output amplifier
- Variable electronic shutter (1/50 to 1/10 000 s)
- Compatible with PAL standard
- Normal or mirror image output available from common output terminal
- Package : 16-pin SDIPICERDIP](WDIPO1 6-N-0500B)

PIN CONNECTIONS

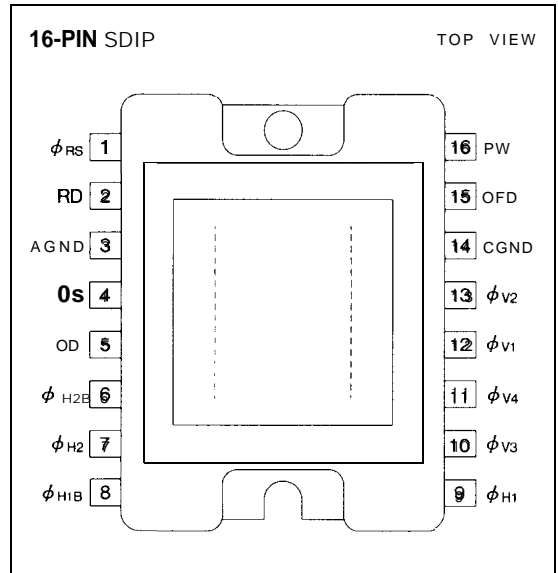

BLOCK DIAGRAM

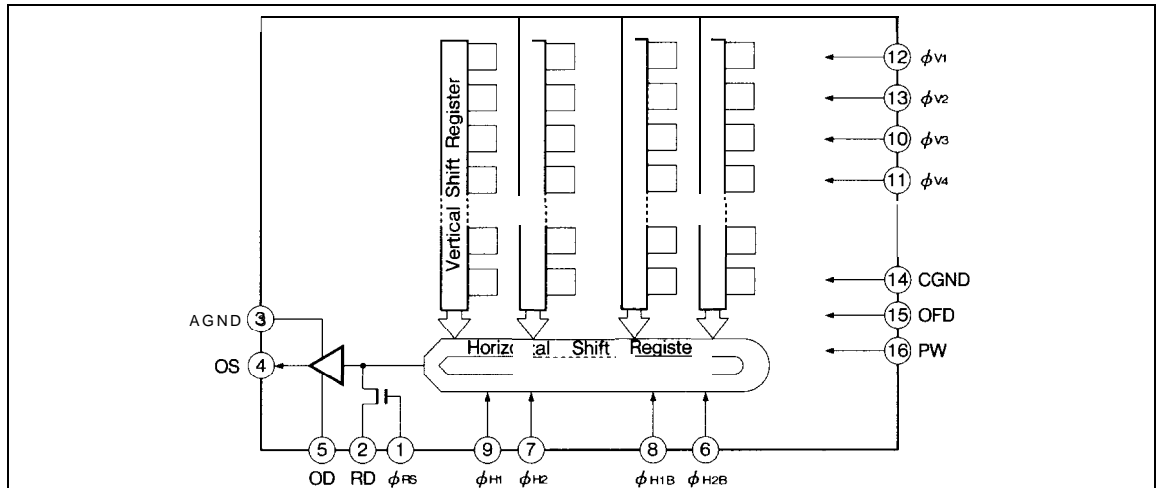

PIN DESCRIPTION

SYMBOL	PIN NAME	NOTE
RD	Reset transistor drain	
OD	Output transistor drain	
Os	Video output	
ϕ_{RS}	Reset transistor gate clink	
$\phi_{V1}, \phi_{V2}, \phi_{V3}, \phi_{V4}$	Vertical shift register gate clock	
$\phi_{H1}, \phi_{H2}, \phi_{H1B}, \phi_{H2B}$	Horizontal shift register gate clock	1
OFD	Overflow drain	
Pw	P type well	
AGND	Analog part ground	
CGND	Clock part ground	

NOTE :

1. Normal image output mode : $\phi_{H1} = \phi_{H1B}, \phi_{H2} = \phi_{H2B}$
 Mirror image output mode : $\phi_{H1} = \phi_{H2B}, \phi_{H2} = \phi_{H1B}$

ABSOLUTE MAXIMUM RATINGS

(Ta = 25°C)

PARAMETER	SYMBOL	RATING	UNIT
Output transistor drain voltage	V _{OD}	Oto +18	v
Reset transistor drain voltage	V _{RD}	Oto +18	v
Overflow drain voltage	V _{Om}	o to +55	v
Reset gate clock voltage	V ϕ_{RS}	-0.3 to +18	v
Vertical shift register clock voltage	V ϕ_V	-9.0 to +18	v
Horizontal shift register clock voltage	V ϕ_H	-0.3 to +18	v
Voltage difference between PW and vertical clock	V _{PW} - V ϕ_V	-27 to 0	v
Storage temperature	T _{stg}	-40 to +85	°C
Operating ambient temperature	T _{opr}	-20 to +70	'c

RECOMMENDED OPERATING CONDITIONS

PARAMETER		SYMBOL	MIN.	TYP.	MAX.	UNIT	NOTE
Operating ambient temperature		Topr		25.0		°C	
Output transistor drain voltage		V _{OD}	14,5	15.0	16,0	v	
Reset transistor drain voltage		V _{RD}		V _{OD}		V	
Overflow drain voltage	When DC is applied	V _{OM}	5.0		19.0	v	1
	When pulse is applied p-p level	V _{φ OFD}	22.0			v	2
Ground		AGND, CGND		0.0		V	
P-well voltage		VPW	- 9.0		V _{φ VL}	V	
Vertical shift register clock	LOW level	V _{φ V1-4L}	- 8.5	- 8.0	-7.5	V	
	INTERMEDIATE level	V _{φ V1-4I}		0.0		v	
	HIGH level	V _{φ V1H} , V _{φ V3H}	16,0	16,5	17.0	v	
Horizontal shift register clock	LOW level	V _{φ VH1-2L} , V _{φ H1B-2BL}	- 0.05	0.0	0.05	v	
	HIGH level	V _{φ VH1-2H} , V _{φ H1B-2BH}	4.7	5.0	6.0	v	
Reset gate clock	LOW level	V _{φ RSL}	0.0		V _{RD} -12.0	v	
	HIGH level	V _{φ RSH}	V _{RD} -7,5		9.5	v	
Vertical shift register clock frequency		f _{φ V1-4}		15.63		KHz	
Horizontal shift register clock frequency		f _{φ H1-2} , f _{φ H1B-2B}		9.66		MHz	
Reset gate clock frequency		f _{φ RS}		9.66		MHz	
Horizontal shift register clock phase		tw ₁ , tw ₂	0.0	5.0	10.0	ns	3

NOTES :

1. When DC voltage is applied, shutter speed is 1 /50 seconds.
2. When pulse is applied, shutter speed is less than 1 /50 seconds.
- 3.

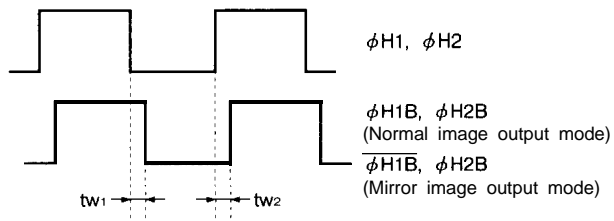

ELECTRICAL CHARACTERISTICS (Drive method : Field Accumulation)

(Ta = 25°C, Operating conditions : typical values for the recommended operating conditions, Color temperature of light source :3200 K / IR cut-off filter (CM-500, 1 mmt))

PARAMETER	SYMBOL	MIN.	TYP.	MAX.	UNIT	NOTE
Photo response non-uniformity	PRNU			10	%	2
Carrier saturation	Vsat	350	450		mV	3
Dark output voltage	Vdark		0.3	3.0	mV	1, 4
Dark signal non-uniformity	DSNU		0.6	2.0	mV	1, 5
Sensitivity	R	240	300		mV	6
Gamma	Y		1			
Smear ratio	SMR		-81	-76	dB	7
Image lag	AI			1.0	00	8
Blooming suppression ratio	ABL	1000				9
Output transistor drain current	I _{OD}		4.0	8.0	mA	
Output impedance	R _o		300		Ω	
Dark noise	V _{noiae}		0.2	0.4	mV	10
OB difference in level				1.0	mV	11
Vector breakup				10.0	°, %	12
Line crawling				3.0	%	13
Luminance flicker				2.0	%	14

- The standard output voltage is defined as 150mV by the average output voltage under uniform illumination.
- The standard exposure level is defined when the average output voltage is 150 mV under uniform illumination.
- V_{OFD} should be adjusted to the minimum voltage with that ABL satisfy the specification.

NOTES :

- 1 Ta : + 60°C
- 2 The image area is divided into 10x 10 segments. The segment's voltage is the average output voltage of all the pixels within the segment. PRNU is defined by $(V_{max} - V_{min})/V_o$, where V_{max} and V_{min} are the maximum and the minimum values of each segment's voltage respectively, when the average output voltage V_o is 150 mV.
- 3 The output voltage measured at the carrier peak when the carrier signal reaches maximum.
- 4 The average output voltage under a non-exposure condition.
- 5 The image area is divided into 10X 10 segments. DSNU is defined by $(V_{dmax} - V_{dmin})$ under the non-exposure condition where V_{dmax} and V_{dmin} are the maximum and the minimum values of each segment's voltage, respectively, that is the average output voltage over all pixels in the segment.
- 6 The average output voltage when a 1000 lux light source attached with a 90% reflector is imaged by a lens of F4, f50 mm.
7. The sensor is adjusted to position a V/I O square at the center of image area where V is the vertical length of the image area. SMR is defined by the ratio of the output voltage detected during the vertical blanking period to the maximum of the pixel voltage in the V/I O square.
8. The sensor is exposed at the exposure level corresponding to the standard condition preceding non-exposure condition. AI is defined by the ratio between the output voltage measured at the 1st field during the non-exposure period and the standard output voltage.
9. The sensor is adjusted to position a V/I O square at the center of image area. ABL is the ratio between the exposure at the standard condition and the exposure at a point where a blooming is observed.
10. The RMS value of the dark noise (after CDS). The bandwidth range is from 1 00 kHz to 5.0 MHz. SC trap on.
11. The difference between the average output voltage of the effective area and the OB part under the non-exposure condition.
12. Observed with a vector scope when the color bar chart is imaged under the standard exposure condition.
13. The difference between the average output voltage of the (Mg + Ye), (G+ Cy) line and the (Mg + Cy), (G + Ye) line under the standard exposure condition.
14. The difference between the average output voltage of the odd field and the even field.

PIXEL STRUCTURE

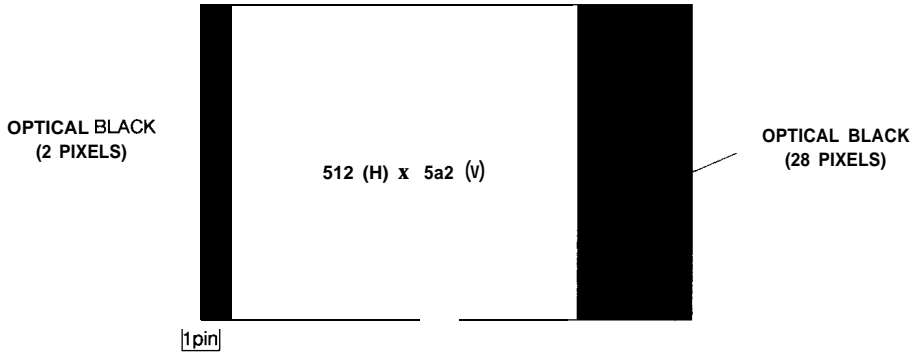

COLOR FILTER ARRAY

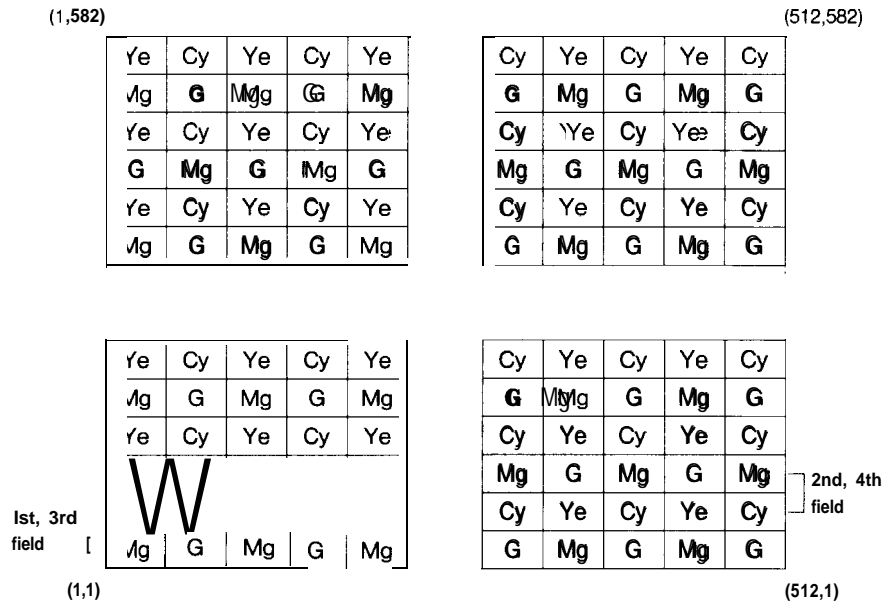

TIMING DIAGRAM EXAMPLE

VERTICAL TRANSFER TIMING < NORMAL OUTPUT > Shutter speed
1/loom s

(1st, 3rd FIELD)

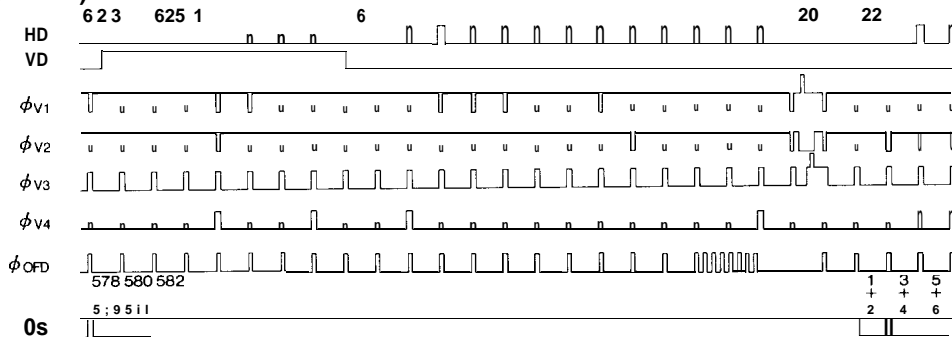

(2nd, 4th FIELD)

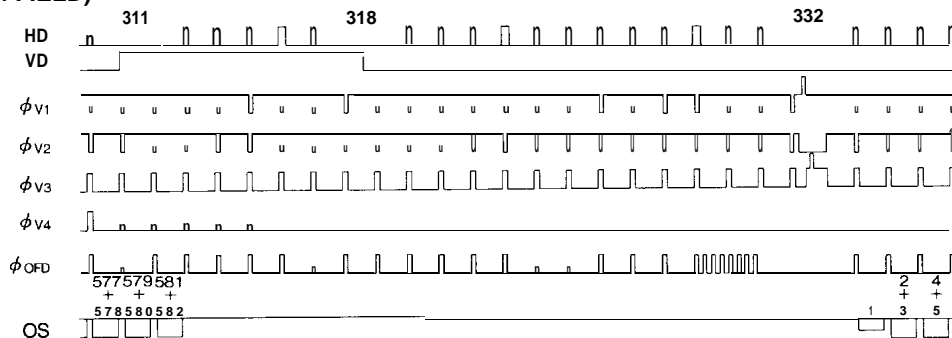

HORIZONTAL TRANSFER TIMING < NORMAL OUTPUT >

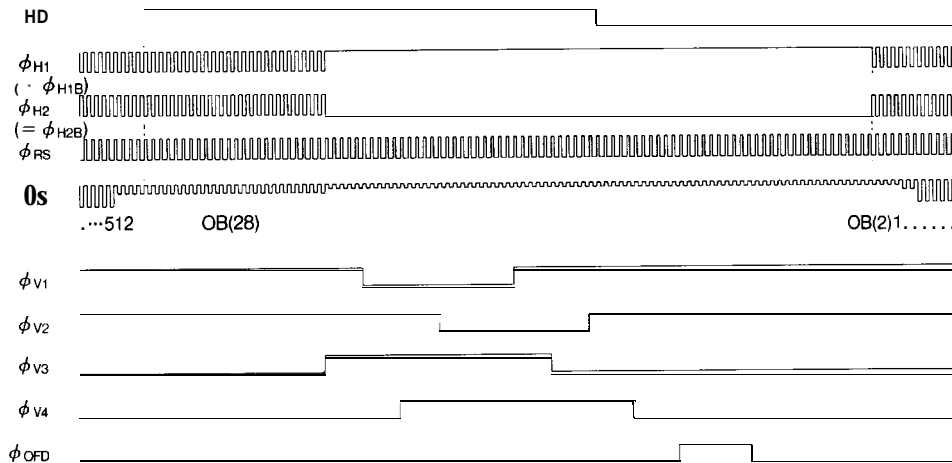

CCD AREA SENSORS

2

VERTICAL TRANSFER TIMING < MIRROR OUTPUT > Shutter speed

1/10 000 s

(1st, 3rd FIELD)

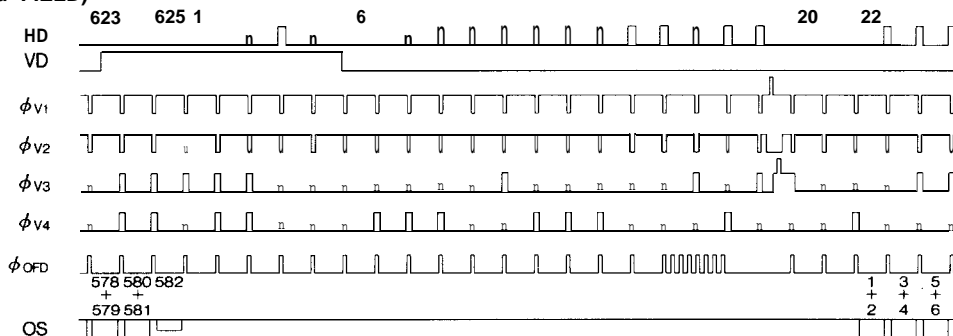

(2nd, 4th FIELD)

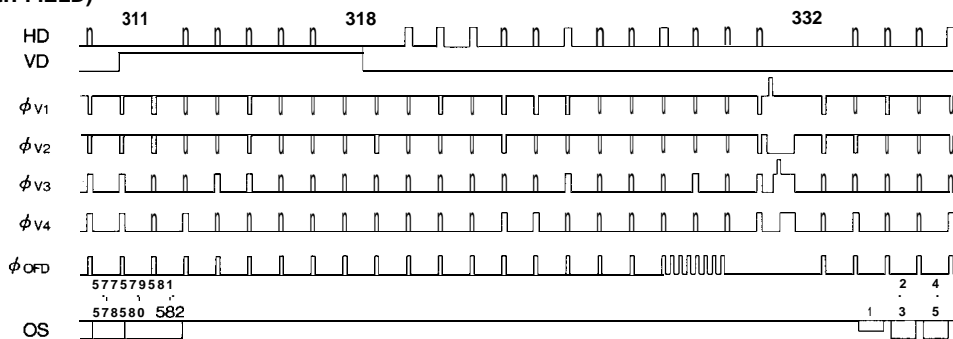

HORIZONTAL TRANSFER TIMING < MIRROR OUTPUT >

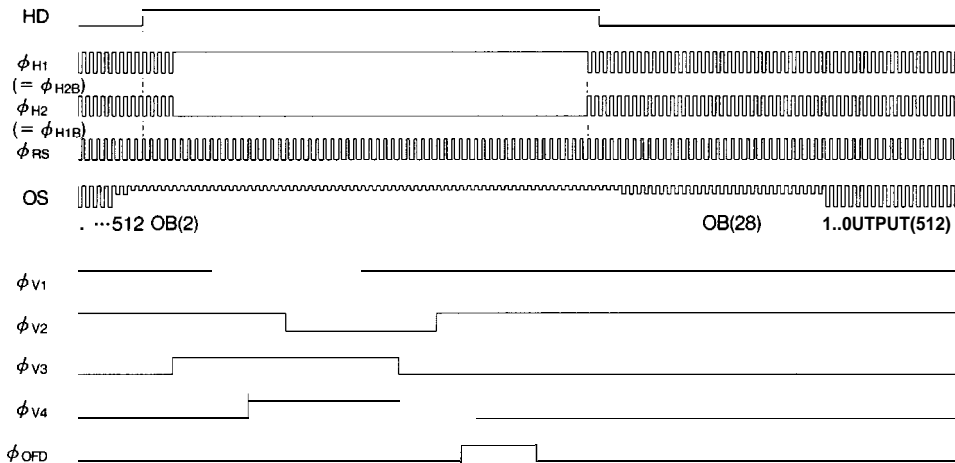

SYSTEM CONFIGURATION EXAMPLE

